

DS8100 High Performance Laser Scanner

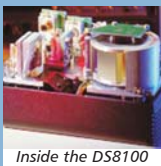

General Description

Datalogic patented technologies, innovations and top performance are the main features of the DS8100, the most powerful bar code reader on the market.

The DS8100 scanner has been designed to offer the best performance and advanced solutions for the most demanding applications in the Material Handling and Sorting Systems fields.

The omni-directional reading stations based on the DS8100 capture medium/high density codes on very fast conveyors with a very large reading area and a minimum gap of 50 mm (2 in) between 2 parcels.

ASTRA™ technology (Automatically SwiTched Reading Area) sets a standard for reading performance. Based on a multi-laser architecture and without a mechanical focusing system, ASTRA™ unites the reading performance of many independent readers in just one scanner, providing reliability and durability benefits.

Successful and proven **ACR™** technology is combined with **PackTrack™** to reduce the distance between two objects and increase the system throughput. The DS8100 also provides almost a 100% read rate on codes covered by plastic film. Other features include high speed integrated oscillating mirror models programmable through the standard software.

Thanks to its superior technology, the DS8100 is considered a market benchmark. It is used in many different applications worldwide in the Transportation & Logistics industry and is the best solution for parcel & freight, postal and BHS applications in airports. With the DS8100, Datalogic has set a standard for industrial Auto-ID.

Features

- > ASTRA™ technology with multi-laser and fixed optic architecture
- > 1,000 mm (40 in) depth of field on high resolution codes
- > Very high scan rate: up to 2,000 scans/sec
- > Integrated PackTrack™ for gap reduction between 2 parcels
- > WINHOST™ setup program
- > High performance software programmable oscillating mirror

Applications

- > Parcel sorting system
- > Postal applications
- > Automatic baggage handling
- > Cargo applications
- > Loading/unloading systems

Specifications

ELECTRICAL CHARACTERISTICS

POWER SUPPLY	20 to 30 Vdc
POWER CONSUMPTION	35 W*

MECHANICAL CHARACTERISTICS

DIMENSIONS	215.5 x 170.5 x 126.5 mm (8.48 x 6.71 x 4.98 in)*
WEIGHT	5.0 Kg (11 lbs) approx.*
CASE MATERIAL	Aluminium

PERFORMANCE

LIGHT SOURCE	Visible Laser Diode (650 nm)
LIGHT RECEIVER	Avalanche photodiode
MAX. RESOLUTION CODE	0.20 mm (8 mils)
SCAN RATE	1,000 (2,000) scans per second
MAX. DEPTH OF FIELD	1,000 mm (40 in) on 0.30 mm (12 mils) codes 1,500 mm (60 in) on 0.50 mm (20 mils) codes
MAX. READING DISTANCE	1,500 mm (60 in) on 0.30 mm (12 mils) codes 2,000 mm (80 in) on 0.50 mm (20 mils) codes
READABLE CODES	22 symbologies incl. 2/5 family, Code 39, Code 93, Code 128, EAN/UPC, Codabar
CODE AUTODISCRIMINATION	Up to 10 different codes
SERIAL INTERFACE CARD	Main interface RS232/RS485/20 mA C.L. Baud rate 1,200 to 57,600 bauds Aux. interface RS232/RS485
BUS INTERFACE CARD	Main interface LONWORK Baud rate 1.250 Mb/sec Aux. interface RS232
INPUT SIGNALS	2x 'Presence sensor' and 1 auxiliary (NPN/PNP transistor)
OUTPUT SIGNALS	'No read', 'Right code' and 1 auxiliary (NPN transistor open collector and emitter)
SET UP	Built in keypad and menu driven display / Via serial port and Windows™ based software program
OPERATING MODES	'On line', 'Serial on line', 'Automatic', 'PackTrack', 'Test'
DISPLAY	2 line by 20 character LCD
KEYPAD	4 keys
LED INDICATORS	4 LED status indicators
LASER CLASSIFICATION	IEC 825 Class 2
LASER CONTROL	Security system to turn laser Off in case of motor slow down or failure
ENVIRONMENT	
OPERATING TEMPERATURE	0 to 45 °C (32 to 113 °F)
STORAGE TEMPERATURE	-20 to 70 °C (-4 to 158 °F)
HUMIDITY	90% non condensing
VIBRATION RESISTANCE	IEC 68-2-6 test FC 1.5 mm, 10 to 55 Hz; 2 hours on each axis
SHOCK RESISTANCE	IEC 68-2-27 test EA 30 G 11 ms; 3 shocks on each axis
PROTECTION CLASS	IP64 (IP65 optional)

*Please refer to the user manual for information on oscillating mirror models

Dimensions

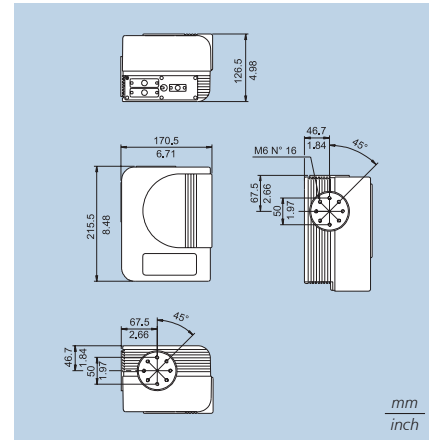

Reading Diagrams

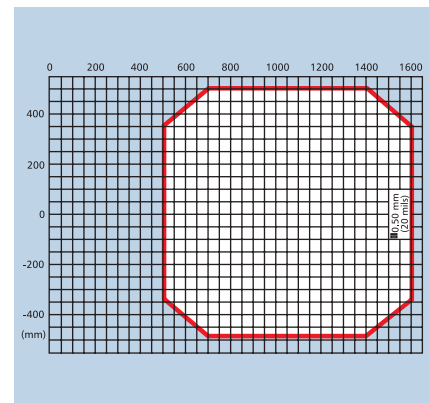

DS8100-2X00

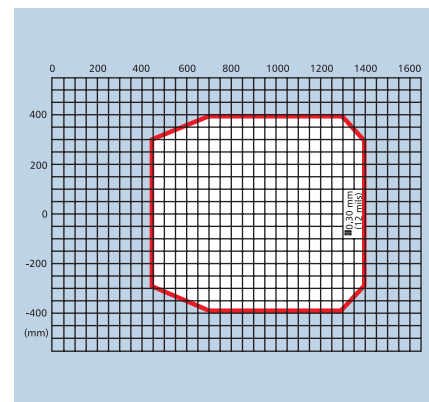

DS8100-4X00



Product and Company names and logos referenced may be either trademarks or registered trademarks of their respective companies. We reserve the right to make modifications and improvements.

